

NEW MODEL OUTLINE

4WD System

The 4WD model uses a full-time 4WD system that constantly distributes torque at a ratio of 50:50 to the front and rear axles.

- The MF2A transfer is lightweight and simple.
- The F17SU rear differential is used.

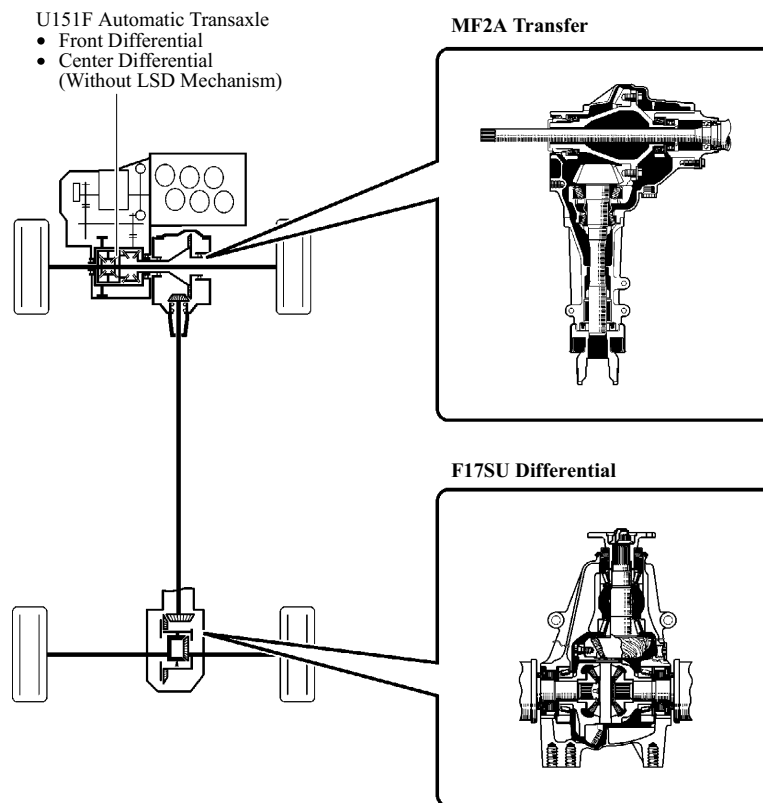

06J0M057C

Rear Differential Type	F17SU
Gear Ratio	2.928
Ring Gear Size	170 mm (6.7 in.)